

Load Rating Chart

Model 45110T



© Manitex 2000

NOTE: Additional copies of this Load Rating Chart can be purchased from your Manitex Distributor. When ordering, use the part number shown in the bottom left corner of this page.

LMI OPERATING CODES

CODE	CRANE CONFIGURATION	OUTRIGGER CONFIGURATION	AREA OF OPERATION
#1	— MAIN BOOM — — — — —	FULLY EXTENDED — — — — —	OVER REAR
#2	— MAIN BOOM — — — — —	FULLY EXTENDED — — — — —	180° OVER REAR
#3	— MAIN BOOM —FOR BOOM STOW & OUT OF STOW—	ALL O/R CONFIGURATIONS —	FULL 360°
#4	— MAIN BOOM — — — — —	MID POSITION — — — — —	180° OVER REAR
#5	— MAIN BOOM — — — — —	RETRACTED — — — — —	180° OVER REAR
#6	— MAIN BOOM — — — — —	ON TIRES — — — — —	DIRECTLY OVER REAR
#7	— RETRACTED JIB 0° OFFSET — — — — —	FULLY EXTENDED — — — — —	OVER REAR
#8	— RETRACTED JIB 0° OFFSET — — — — —	FULLY EXTENDED — — — — —	180° OVER REAR
#9	— RETRACTED JIB 15° OFFSET — — — — —	FULLY EXTENDED — — — — —	OVER REAR
#10	— RETRACTED JIB 15° OFFSET — — — — —	FULLY EXTENDED — — — — —	180° OVER REAR
#11	— RETRACTED JIB 30° OFFSET — — — — —	FULLY EXTENDED — — — — —	OVER REAR
#12	— RETRACTED JIB 30° OFFSET — — — — —	FULLY EXTENDED — — — — —	180° OVER REAR
#13	— EXTENDED JIB 0° OFFSET — — — — —	FULLY EXTENDED — — — — —	OVER REAR
#14	— EXTENDED JIB 0° OFFSET — — — — —	FULLY EXTENDED — — — — —	180° OVER REAR
#15	— EXTENDED JIB 15° OFFSET — — — — —	FULLY EXTENDED — — — — —	OVER REAR
#16	— EXTENDED JIB 15° OFFSET — — — — —	FULLY EXTENDED — — — — —	180° OVER REAR
#17	— EXTENDED JIB 30° OFFSET — — — — —	FULLY EXTENDED — — — — —	OVER REAR
#18	— EXTENDED JIB 30° OFFSET — — — — —	FULLY EXTENDED — — — — —	180° OVER REAR
#19	— RETRACTED JIB 0° OFFSET — — — — —	MID POSITION — — — — —	180° OVER REAR
#20	— RETRACTED JIB 15° OFFSET — — — — —	MID POSITION — — — — —	180° OVER REAR
#21	— RETRACTED JIB 30° OFFSET — — — — —	MID POSITION — — — — —	180° OVER REAR
#22	— EXTENDED JIB 0° OFFSET — — — — —	MID POSITION — — — — —	180° OVER REAR
#23	— EXTENDED JIB 15° OFFSET — — — — —	MID POSITION — — — — —	180° OVER REAR
#24	— EXTENDED JIB 30° OFFSET — — — — —	MID POSITION — — — — —	180° OVER REAR
#25	— PERSONNEL LIFTING MAIN BOOM — — — — —	FULLY EXTENDED — — — — —	180° OVER REAR
#26	— PERSONNEL LIFTING RETR JIB 0° OFFSET — — — — —	FULLY EXTENDED — — — — —	180° OVER REAR
#27	— PERSONNEL LIFTING RETR JIB 15° OFFSET — — — — —	FULLY EXTENDED — — — — —	180° OVER REAR
#28	— PERSONNEL LIFTING RETR JIB 30° OFFSET — — — — —	FULLY EXTENDED — — — — —	180° OVER REAR
#29	— PERSONNEL LIFTING EXTENDED JIB 0° OFFSET — — — — —	FULLY EXTENDED — — — — —	180° OVER REAR
#30	— PERSONNEL LIFTING EXTENDED JIB 15° OFFSET — — — — —	FULLY EXTENDED — — — — —	180° OVER REAR
#31	— PERSONNEL LIFTING EXTENDED JIB 30° OFFSET — — — — —	FULLY EXTENDED — — — — —	180° OVER REAR

WARNING

1. THE OPERATOR MUST READ AND UNDERSTAND THE OWNER'S MANUAL BEFORE OPERATING THIS CRANE.

2. POSITIONING OR OPERATION OF CRANE BEYOND AREAS SHOWN ON THIS CHART IS NOT INTENDED OR APPROVED EXCEPT WHERE SPECIFIED IN OWNER'S MANUAL.

3. LOADED BOOM ANGLES AT SPECIFIED BOOM LENGTHS GIVE ONLY AN APPROXIMATION OF THE OPERATING RADIUS. THE BOOM ANGLE BEFORE LOADING SHOULD BE GREATER TO ACCOUNT FOR DEFLECTIONS. DO NOT EXCEED THE OPERATING RADIUS FOR RATED LOADS.

4. THE OPERATING RADIUS SHOWN IN THE JIB RATING CHART IS FOR FULLY EXTENDED BOOM ONLY. WHEN BOOM IS NOT FULLY EXTENDED, USE ONLY LOADED BOOM ANGLE TO DETERMINE LOAD RATING OF JIB.

5. FOR BOOM ANGLES NOT SHOWN ON JIB LOAD RATING CHART, USE RATING OF NEXT LOWER BOOM ANGLE.

WARNING (CONTINUED)

6. FOR BOOM LENGTHS NOT SHOWN, USE RATING OF NEXT SHORTER OR LONGER BOOM LENGTH, WHICHEVER IS LESS. FOR RADII NOT SHOWN, USE RATING OF NEXT LONGER RADIUS.
7. CRANE LOAD RATINGS ON OUTRIGGERS ARE BASED ON FREELY SUSPENDED LOADS WITH THE MACHINE LEVELED AND STANDING ON A FIRM UNIFORM SUPPORTING SURFACE. NO ATTEMPT SHALL BE MADE TO MOVE A LOAD HORIZONTALLY ON THE GROUND IN ANY DIRECTION.
8. PRACTICAL WORKING LOADS DEPEND ON SUPPORTING SURFACE, WIND, AND OTHER FACTORS AFFECTING STABILITY SUCH AS HAZARDOUS SURROUNDINGS, EXPERIENCE OF PERSONNEL, AND PROPER HANDLING, ALL OF WHICH MUST BE TAKEN INTO ACCOUNT BY THE OPERATOR.
9. THE MAXIMUM LOAD WHICH MAY BE TELESCOPED IS LIMITED BY HYDRAULIC PRESSURE, BOOM ANGLE, AND BOOM LUBRICATION. IT IS SAFE TO ATTEMPT TO TELESCOPE ANY LOAD WITHIN THE LIMITS OF THE LOAD RATING CHART.

INFORMATION

1. DEDUCTIONS MUST BE MADE FROM RATED LOADS FOR JIBS, OPTIONAL ATTACHMENTS, HOOKS, AND LOADBLOCKS (SEE DEDUCTION CHART). WEIGHTS OF SLINGS AND ALL OTHER LOAD HANDLING DEVICES SHALL BE CONSIDERED A PART OF THE LOAD.
2. LOAD RATINGS ABOVE THE HEAVY LINE ARE STRUCTURALLY LIMITED CAPACITIES. LOAD RATINGS BELOW THE HEAVY LINE ARE STABILITY LIMITED CAPACITIES AND DO NOT EXCEED 85 % OF TIPPING.

DEFINITIONS

1. OPERATING RADIUS IS THE HORIZONTAL DISTANCE FROM THE AXIS OF ROTATION TO THE CENTER OF THE VERTICAL HOIST LINE OR TACKLE WITH LOAD APPLIED.
2. LOADED BOOM ANGLE IS THE INCLUDED ANGLE BETWEEN THE HORIZONTAL AND LONGITUDINAL AXES OF THE BOOM BASE AFTER LIFTING RATED LOAD AT RATED RADIUS.

ALLOWABLE LINE PULL										WARNING
1 PART LINE	2 PART LINE	3 PART LINE	4 PART LINE	5 PART LINE	6 PART LINE	7 PART LINE	8 PART LINE	9 PART LINE	10 PART LINE	
										<p>ANTI-TWO-BLOCK SYSTEM MUST BE IN GOOD OPERATING CONDITION BEFORE OPERATING CRANE.</p> <p>REFER TO THE OWNER'S MANUAL.</p> <p>KEEP AT LEAST 3 WRAPS OF LOAD LINE ON THE DRUM AT ALL TIMES.</p>
10000 LBS	20000 LBS	30000 LBS	40000 LBS	50000 LBS	60000 LBS	70000 LBS	80000 LBS	89900 LBS	89900 LBS	5/8" XLT4 LOW-TORQUE (3.5:1 SF) - 35000 LBS MIN BREAKING STRENGTH

AREA OF OPERATIONS

ON TIRES

WHEN LIFTING ON TIRES, THE BOOM MUST BE CENTERED OVER THE REAR OF THE CRANE WITH THE SWING BRAKE AND THE HOUSELOCK ENGAGED.

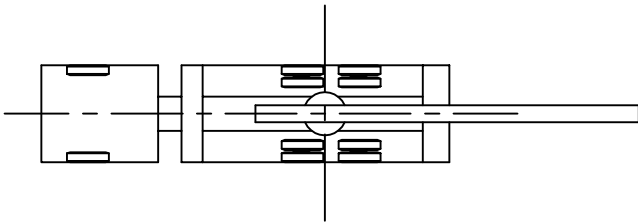

ON OUTRIGGERS

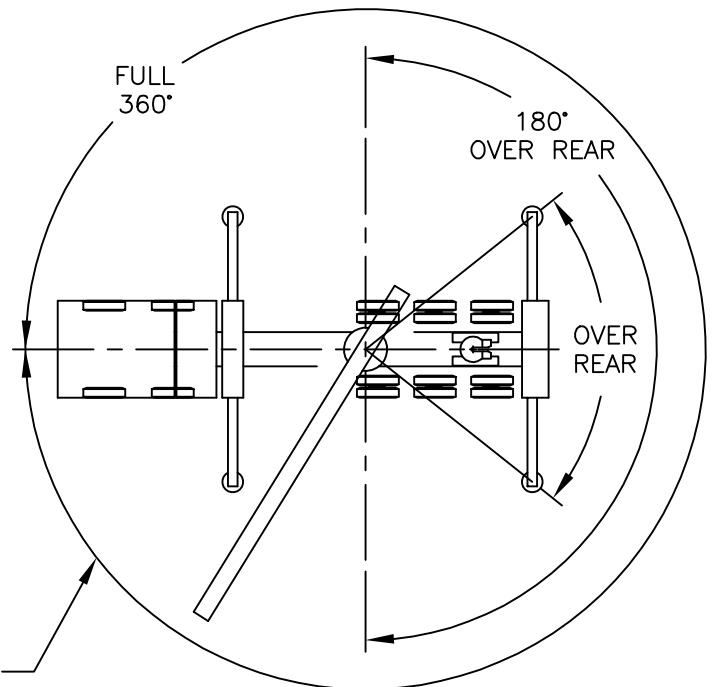

FULL 360° AREA OF OPERATION IS ONLY ALLOWED WITH RETRACTED BOOM FOR STORAGE. NO LOADS ARE TO BE LIFTED OVER THE FRONT OTHER THAN EMPTY HOOK BLOCK AND STOWED JIB.

DEDUCTIONS FROM RATED LOADS FOR LOAD HANDLING DEVICES SUPPLIED BY MANITEX

AUXILIARY BLOCK	-----	50 LBS
ROOSTER SHEAVE	-----	70 LBS
LIFTING FROM MAIN BOOM WITH JIB STOWED OR ERECTED	-----	SEE LOAD CHART
OVERHAUL BALL	-----	SEE MANUFACTURER NAMEPLATE
LOAD BLOCK	-----	SEE MANUFACTURER NAMEPLATE

- RANGE DIAGRAM -

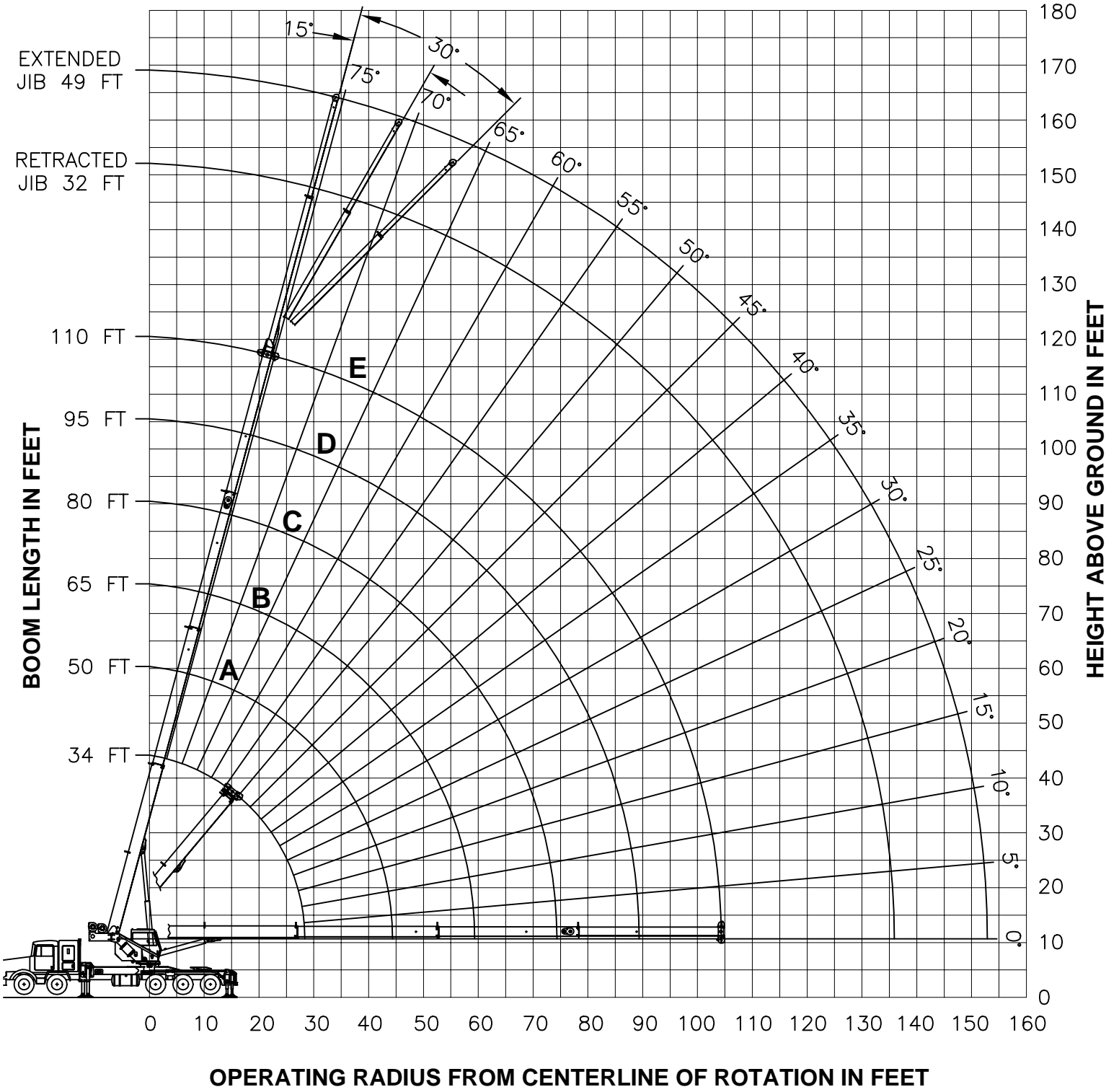

**USE THIS CHART ONLY WHEN
ALL OUTRIGGER BEAMS ARE
FULLY EXTENDED**

PINS MUST BE
DISENGAGED FOR
THIS OUTRIGGER
CONFIGURATION

OUTRIGGER
BEAMS MUST
BE EXTENDED
TO MARK

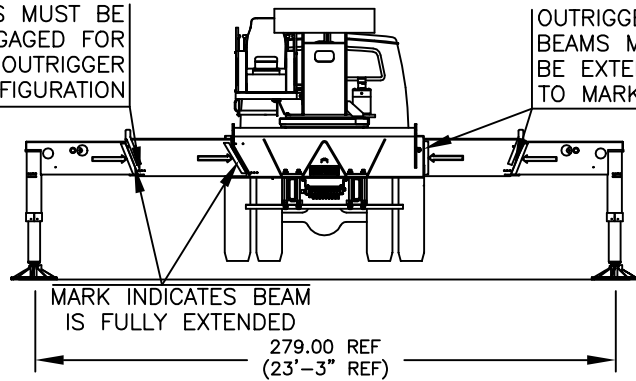

MAIN BOOM LIFTING CAPACITIES

LOAD RADIUS (FT)	BOOM LENGTH 34 FT			BOOM LENGTH 50 FT (A)			BOOM LENGTH 65 FT (B)			
	LOADED BOOM ANGLE (DEG)	CODE 1	CODE 2	LOADED BOOM ANGLE (DEG)	CODE 1	CODE 2	LOADED BOOM ANGLE (DEG)	CODE 1	CODE 2	
		OVER REAR (LBS)	180° OVER REAR (LBS)		OVER REAR (LBS)	180° OVER REAR (LBS)		OVER REAR (LBS)	180° OVER REAR (LBS)	
6	71	89900	89900							
8	67.5	88100	88100							
10	63.5	77900	77900	73	51000	51000				
12	60	69900	69900	70.5	51000	51000				
15	53.5	56000	56000	67	51000	51000	73	40000	40000	
20	42	41800	41800	60.5	42400	42400	68.5	38810	38810	
25	26.5	34300	34300	53.5	35000	35000	63.5	33150	33150	
30				45.5	29070	29070	58.5	29000	29000	
35				36.5	24120	22080	53	24500	22590	
40				25	20370	17220	47	20770	17740	
45							40.5	17850	14330	
50							32.5	15500	11800	
55							22.5	13550	9840	DEDUCT FOR JIB FROM MAIN BOOM CAPACITIES
		1150 LBS		780 LBS		600 LBS		STOWED JIB		
		2940 LBS		2650 LBS		2510 LBS		ERECTED JIB (RETRACTED)		
		3320 LBS		2910 LBS		2710 LBS		ERECTED JIB (EXTENDED)		

LOAD RADIUS (FT)	BOOM LENGTH 80 FT (C)			BOOM LENGTH 95 FT (D)			BOOM LENGTH 110 FT (E)			
	LOADED BOOM ANGLE (DEG)	CODE 1	CODE 2	LOADED BOOM ANGLE (DEG)	CODE 1	CODE 2	LOADED BOOM ANGLE (DEG)	CODE 1	CODE 2	
		OVER REAR (LBS)	180° OVER REAR (LBS)		OVER REAR (LBS)	180° OVER REAR (LBS)		OVER REAR (LBS)	180° OVER REAR (LBS)	
20	73.5	28230	28230							
25	69.5	24350	24350	73.5	20000	20000				
30	65.5	21280	21280	70.5	18680	18680	74	15500	15500	
35	61.5	19000	19000	67.5	16580	16580	71.5	14660	14660	
40	57.5	16870	16870	64	14820	14820	69	13270	13270	
45	53	15120	14600	60.5	13330	13330	66	11960	11960	
50	48	13600	12070	57	12050	12050	63	10850	10850	
55	43	12310	10120	53	10920	10290	60	9950	9950	
60	37	11200	8570	49	10000	8740	56.5	9210	8850	
65	30	10240	7310	44.5	9300	7480	53.5	8410	7590	
70	21	9620	6250	40	8520	6430	50	7700	6540	
75				34.5	7800	5550	46	7060	5660	
80				28	7180	4790	42	6480	4900	
85				20	6620	4120	37.5	5960	4250	
90							33	5490	3680	
95							27	5070	3170	
100							19	4680	2710	DEDUCT FOR JIB FROM MAIN BOOM CAPACITIES
		490 LBS		420 LBS		360 LBS		STOWED JIB		
		2420 LBS		2360 LBS		2320 LBS		ERECTED JIB (RETRACTED)		
		2580 LBS		2500 LBS		2430 LBS		ERECTED JIB (EXTENDED)		

**USE THIS CHART ONLY WHEN
ALL OUTRIGGER BEAMS ARE
IN THE MID POSITION**

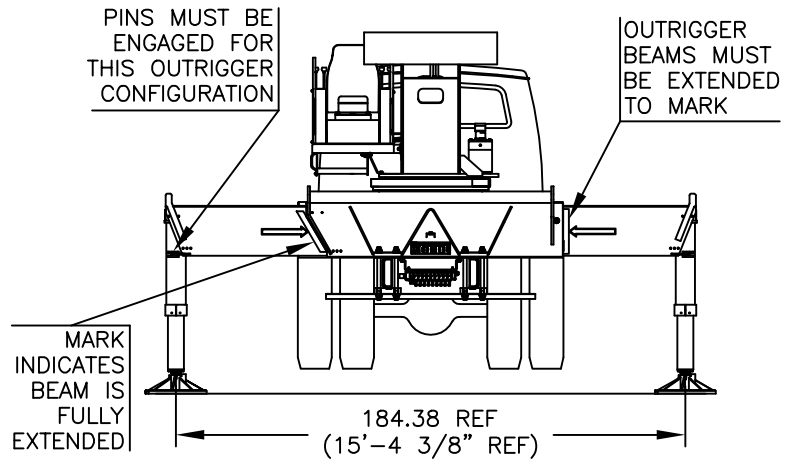

MAIN BOOM LIFTING CAPACITIES

LMI CODE 4													
LOAD RADIUS (FT)	BOOM LENGTH 34 FT		BOOM LENGTH 50 FT (A)		BOOM LENGTH 65 FT (B)		BOOM LENGTH 80 FT (C)		BOOM LENGTH 95 FT (D)		BOOM LENGTH 110 FT (E)		DEDUCTIONS FOR JIB FROM MAIN BOOM CAPACITIES
	LOADED BOOM ANGLE (DEG)	180° OVER REAR (LBS)	LOADED BOOM ANGLE (DEG)	180° OVER REAR (LBS)	LOADED BOOM ANGLE (DEG)	180° OVER REAR (LBS)	LOADED BOOM ANGLE (DEG)	180° OVER REAR (LBS)	LOADED BOOM ANGLE (DEG)	180° OVER REAR (LBS)	LOADED BOOM ANGLE (DEG)	180° OVER REAR (LBS)	
6	71	89900											
8	67.5	88100											
10	63.5	77900	73	51000									
12	60	69900	70.5	51000									
15	53.5	50890	67	51000	73	40000							
20	42	27770	60.5	28950	68.5	29500	73.5	28230					
25	26.5	17940	53.5	19040	63.5	19510	69.5	19800	73.5	19990			
30			45.5	13550	58.5	13990	65.5	14250	70.5	14430	74	14550	
35			36.5	10060	53	10490	61.5	10730	67.5	10900	71.5	11010	
40			25	7620	47	8060	57.5	8300	64	8460	69	8570	
45					40.5	6280	53	6520	60.5	6670	66	6780	
50					32.5	4910	48	5160	57	5310	63	5410	
55					22.5	3820	43	4080	53	4230	60	4330	
60							37	3200	49	3350	56.5	3450	
65							30	2470	44.5	2630	53.5	2730	
70							21	1850	40	2020	50	2120	
75									34.5	1500	46	1600	
80									28	1050	42	1150	
85													
	1150 LBS		780 LBS		600 LBS		490 LBS		420 LBS		360 LBS		STOWED JIB
	2940 LBS		2650 LBS		2510 LBS		2420 LBS		2360 LBS		2320 LBS		ERECTED JIB (RETRACTED)
	3320 LBS		2910 LBS		2710 LBS		2580 LBS		2500 LBS		2430 LBS		ERECTED JIB (EXTENDED)

**USE THIS CHART WHEN ALL
OUTRIGGER BEAMS ARE NOT IN
EITHER THE MID OR FULLY
EXTENDED POSITION**

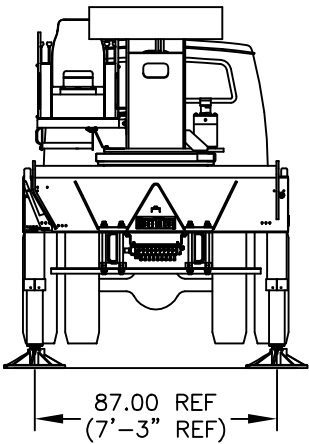

MAIN BOOM LIFTING CAPACITIES

LMI CODE 5													
LOAD RADIUS (FT)	BOOM LENGTH 34 FT		BOOM LENGTH 50 FT (A)		BOOM LENGTH 65 FT (B)		BOOM LENGTH 80 FT (C)		BOOM LENGTH 95 FT (D)		BOOM LENGTH 110 FT (E)		DEDUCTIONS FOR JIB FROM MAIN BOOM CAPACITIES
	LOADED BOOM ANGLE (DEG)	180° OVER REAR (LBS)	LOADED BOOM ANGLE (DEG)	180° OVER REAR (LBS)	LOADED BOOM ANGLE (DEG)	180° OVER REAR (LBS)	LOADED BOOM ANGLE (DEG)	180° OVER REAR (LBS)	LOADED BOOM ANGLE (DEG)	180° OVER REAR (LBS)	LOADED BOOM ANGLE (DEG)	180° OVER REAR (LBS)	
6	71	89900											
8	67.5	45990											
10	63.5	29720	73	30980									
12	60	21220	70.5	22320									
15	53.5	14060	67	15030	73	15490							
20	42	7920	60.5	8810	68.5	9210	73.5	9450					
25	26.5	4600	53.5	5490	63.5	5860	69.5	6090	73.5	6240			
30			45.5	3410	58.5	3780	65.5	4000	70.5	4140	74	4240	
35			36.5	1990	53	2360	61.5	2570	67.5	2710	71.5	2800	
40			25	930	47	1320	57.5	1530	64	1660	69	1760	
45													
		1150 LBS	780 LBS		600 LBS		490 LBS		420 LBS		360 LBS		STOWED JIB

WARNINGS

1. THE JIB MUST BE IN THE STOWED POSITION, IF SO EQUIPPED, WHEN USING THIS OUTRIGGER CONFIGURATION.

**USE THIS CHART
WHEN PICKING
LOADS ON TIRES**

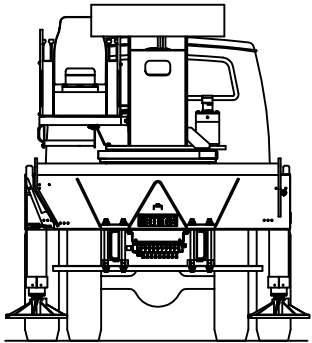

ON TIRE CAPACITIES

WARNINGS

LMI CODE 6			
LOAD RADIUS (FT)	MAX BOOM LENGTH (FT)	BOOM DIRECTLY OVER REAR (LBS)	STOWED JIB DEDUCTION (LBS)
10	34	10000	1150
12	34	9000	1150
15	34	7600	1150
20	34	4650	1150
25	50 (A)	2800	780
30	50 (A)	1550	780

1. CRANE LOAD RATINGS ON TIRES ARE BASED ON THE CRANE BEING LEVEL AND TRAVELING ON A FIRM UNIFORM SURFACE (BLACK TOP, CONCRETE OR SIMILAR SURFACE).
2. TIRES MUST BE INFLATED TO 120 PSI FOR PICKING ON TIRES. CONSULT TRUCK MANUAL FOR PROPER INFLATION PROCEDURE.
3. THE JIB MUST BE IN THE STOWED POSITION, IF SO EQUIPPED, WHEN PICKING ON TIRES.
4. WHEN LIFTING ON TIRES, THE BOOM MUST BE CENTERED OVER THE REAR OF THE CRANE WITH THE SWING BRAKE AND THE HOUSELOCK ENGAGED.
5. KEEP THE LOAD CLOSE TO THE GROUND AND RESTRAINED FROM SWINGING.
6. WHEN THE RADIUS IS BETWEEN LISTED VALUES, USE THE SMALLER OF THE TWO LOAD RATINGS.
7. DO NOT OPERATE AT LONGER RADII THAN THOSE LISTED ON THE LOAD CHART.

**USE THIS CHART ONLY WHEN
ALL OUTRIGGER BEAMS ARE
FULLY EXTENDED**

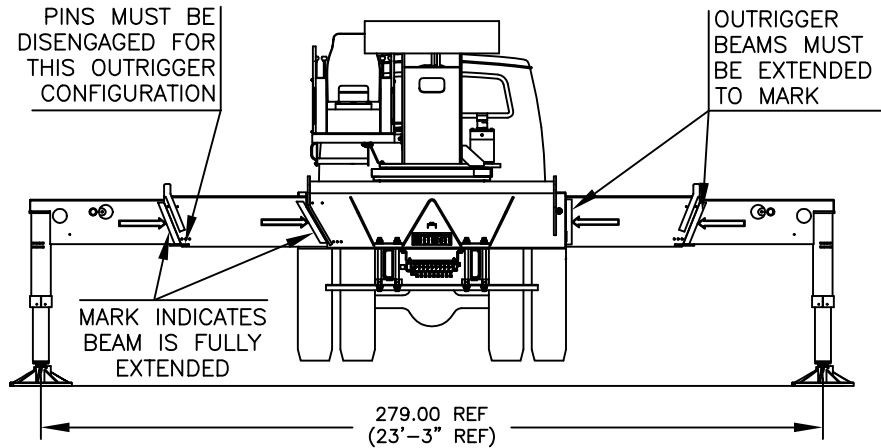

32 FT RETRACTED JIB LIFTING CAPACITIES

LOAD RADIUS (FT)	LOADED BOOM ANGLE (DEG)	0° OFFSET		15° OFFSET			30° OFFSET		
		CODE 7 OVER REAR (LBS)	CODE 8 180° OVER REAR (LBS)	LOADED BOOM ANGLE (DEG)	CODE 9 OVER REAR (LBS)	CODE 10 180° OVER REAR (LBS)	LOADED BOOM ANGLE (DEG)	CODE 11 OVER REAR (LBS)	CODE 12 180° OVER REAR (LBS)
40	74.5	7300	7300						
45	72.5	7300	7300						
50	70.5	7300	7300	73.5	6500	6500			
55	68.5	6980	6980	71.5	6500	6500	74	5800	5800
60	66.5	6600	6600	69.5	6120	6120	72	5750	5750
65	64	6230	6230	67	5780	5780	69.5	5450	5450
70	62	5870	5870	65	5450	5450	67	5160	5160
75	59.5	5530	5530	62.5	5160	5160	64.5	4900	4900
80	57	5110	4850	60	4880	4880	62	4670	4670
85	54.5	4690	4190	57.5	4630	4520	59.5	4450	4450
90	52	4280	3610	54.5	4400	3910	56.5	4250	4140
95	49	3920	3100	51.5	4070	3360	53.5	4070	3560
100	46	3570	2650	48.5	3700	2880	50.5	3820	3050
105	43	3250	2240	45.5	3370	2450	47	3480	2590
110	39.5	2950	1880	42	3050	2060	43.5	3140	2170
115	35.5	2670	1550	38	2770	1700	39	2830	1790
120	31.5	2420	1250	34	2500	1370	34.5	2540	1430
125	26.5	2180	980	29	2240	1070	29	2260	1090
130	20.5	1960		22	2000	780	20	1970	760
135	10	1760							
140									

**USE THIS CHART ONLY WHEN
ALL OUTRIGGER BEAMS ARE
FULLY EXTENDED**

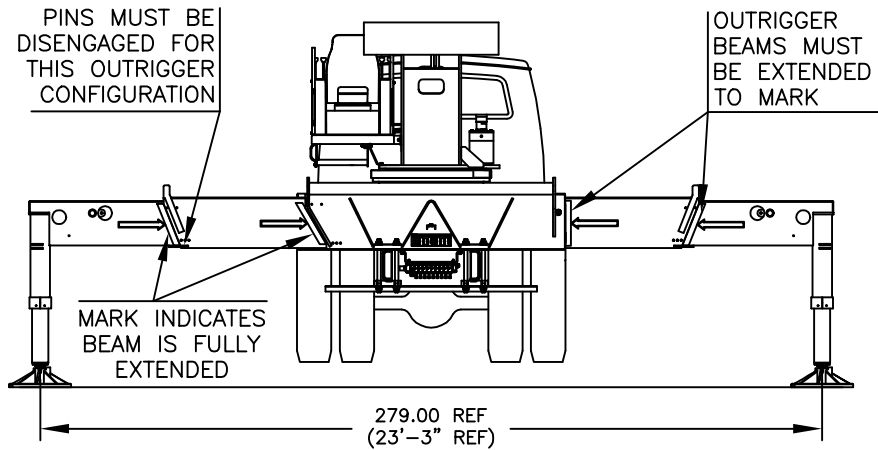

49 FT EXTENDED JIB LIFTING CAPACITIES

LOAD RADIUS (FT)	0° OFFSET			15° OFFSET			30° OFFSET		
	LOADED BOOM ANGLE (DEG)	CODE 13	CODE 14	LOADED BOOM ANGLE (DEG)	CODE 15	CODE 16	LOADED BOOM ANGLE (DEG)	CODE 17	CODE 18
		OVER REAR (LBS)	180° OVER REAR (LBS)		OVER REAR (LBS)	180° OVER REAR (LBS)		OVER REAR (LBS)	180° OVER REAR (LBS)
45	75	5400	5400						
50	73.5	5400	5400						
55	71.5	5400	5400	75	4700	4700			
60	69.5	5400	5400	73.5	4480	4480			
65	68	5230	5230	71.5	4280	4280	75	3520	3520
70	66	4930	4930	69.5	4100	4100	73.5	3410	3410
75	64	4660	4660	67.5	3940	3940	71	3310	3310
80	62	4410	4410	65.5	3790	3790	69	3210	3210
85	60	4170	4170	63.5	3650	3650	67	3130	3130
90	57.5	3950	3950	61.5	3520	3520	64.5	3050	3050
95	55.5	3750	3690	59	3400	3400	62	2980	2980
100	53	3560	3230	57	3290	3290	59.5	2910	2910
105	50.5	3380	2820	54.5	3190	3170	57	2860	2860
110	48	3220	2460	52	3050	2770	54.5	2810	2810
115	45.5	2980	2120	49	2920	2400	51.5	2760	2620
120	42.5	2730	1820	46	2800	2070	48.5	2730	2250
125	39.5	2500	1540	43	2640	1760	45	2650	1910
130	36	2290	1290	39.5	2410	1480	41	2480	1600
135	32	2090	1060	35.5	2190	1220	36.5	2240	1300
140	28	1890	840	31	1970	970	31	2000	1010
145	22.5	1720		25	1770				
150	15	1550		15.5	1570				
155									

**USE THIS CHART ONLY WHEN
ALL OUTRIGGER BEAMS ARE
IN THE MID POSITION**

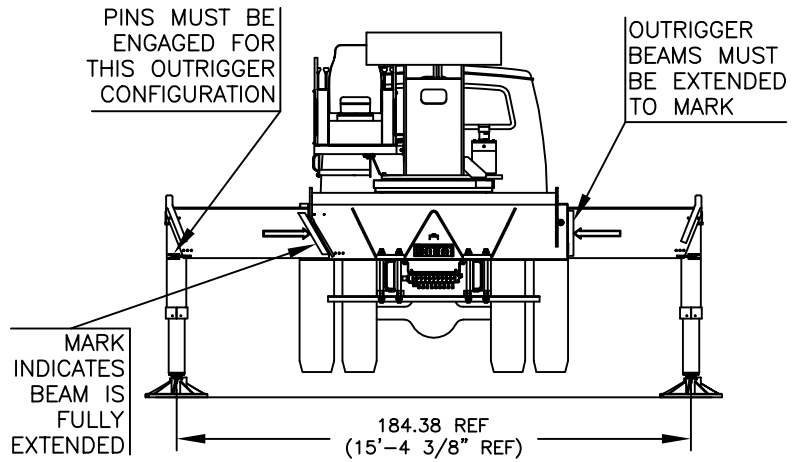

32 FT RETRACTED JIB LIFTING CAPACITIES

LOAD RADIUS (FT)	0° OFFSET		15° OFFSET		30° OFFSET	
	LOADED BOOM ANGLE (DEG)	CODE 19 180° OVER REAR (LBS)	LOADED BOOM ANGLE (DEG)	CODE 20 180° OVER REAR (LBS)	LOADED BOOM ANGLE (DEG)	CODE 21 180° OVER REAR (LBS)
40	74.5	7300				
45	72.5	6730				
50	70.5	5330	73.5	6000		
55	68.5	4230	71.5	4810	74	5320
60	66.5	3340	69.5	3850	72	4300
65	64	2600	67	3060	69.5	3450
70	62	1980	65	2390	67	2730
75	59.5	1450	62.5	1820	64.5	2120
80	57	1000	60	1330	62	1590
85			57.5	900	59.5	1130
90						

49 FT EXTENDED JIB LIFTING CAPACITIES

LOAD RADIUS (FT)	0° OFFSET		15° OFFSET		30° OFFSET	
	LOADED BOOM ANGLE (DEG)	CODE 22 180° OVER REAR (LBS)	LOADED BOOM ANGLE (DEG)	CODE 23 180° OVER REAR (LBS)	LOADED BOOM ANGLE (DEG)	CODE 24 180° OVER REAR (LBS)
45	75	5400				
50	73.5	5400				
55	71.5	4870	75	4700		
60	69.5	3970	73.5	4480		
65	68	3220	71.5	3900	75	3520
70	66	2590	69.5	3210	73.5	3410
75	64	2060	67.5	2620	71	3100
80	62	1600	65.5	2100	69	2540
85	60	1200	63.5	1660	67	2050
90	57.5	850	61.5	1260	64.5	1610
95			59	910	62	1220
100					59.5	880
105						